

Networking and Security Research Center <http://nsrc.cse.psu.edu/>

Mission: Enabling robust, high performance secure internetworked information systems

Professor Thomas F. La Porta, Director
Department of Computer Science and Engineering

College of Engineering

- Computer Science and Engineering, Electrical Engineering
- Networking, communications, all aspects of security, data mining and privacy

Applied Research Lab

- Wireless technologies, networking, security, information fusion
- Classified programs

Smeal College of Business

- Economic and financial analysis, monitoring, security management, and supply chain apps

Dickinson Law School, School of International Affairs

- Policy, legal implications, applications (voting, Internet privacy, etc.)

Great Valley Campus

- Engineering Division, Software Engineering Research Group; ultra-large systems, design for security

Also receive financial support from College of Information Science and Technology

Ben Franklin Center of Excellence

- Designated in January 2007 – June 2009 (maximum duration)
- Total state funding of over \$3M in 4 years

Networking, security and systems experts

- 22 faculty
- Approximately 60 students
 - Ph.D., M.S. and Schreyer Honors College Seniors
 - 3 Labs in addition to individual research groups

Diverse Expertise

- Wireless networking and communications
- Software systems
- Business and law
- All aspects of security: networking, protocols, systems, policies, cryptography

Industrial partners

- Accipiter Systems, Ben Franklin, Boeing, (Bell Labs) Alcatel-Lucent, Vocollect

Additional industrial funding/Internships

- Accipiter, Cisco, IBM, Intel, Motorola, Narus, Raytheon, Vocollect, Sprint, Alcatel-Lucent, Telcordia, Army Research Lab, Lockheed Martin
- Student placements: Cisco, Oracle, Rackspace, Samsung, Broadcom, Palo Alto Networks

Research Results

- ~100 refereed publications in 2009

Funding: over \$17M in new funding in 2005-2009 (over \$3M in 2009)

- Network Sciences Collaborative Technology Alliance Communications Network Center
- NSF: Trustworthy Computing (2), Networking, Cyber-Physical Systems, Computing and Communication Foundations
- Army Research Lab and UK Ministry of Defence (ITA Program)
- Army Research Office (ARO) DURIP, Air Force Research Lab (AFRL), DARPA (ITMANET)
- NSA
- The Technology Collaborative
- Industrial Funding: over \$500K in 2009 (approximately \$1.5M in 5 years)

Faculty Appointments in 2009

- EiC of ACM Transactions on Internet Technology
- Executive Committee on 9 major conferences
- Chair of NSF Workshop on Networked Sensor Systems
- IEEE BoG, Steering Committee of top IEEE Networking and Mobility Journals
- Associate Editors on 10 publications

NSF Presidential Early Career Awards for Scientists and Engineers (PECASE) – 25 awarded

Recognition of potential for leadership across the frontiers of scientific knowledge

- **Adam Smith**: data access and privacy: new approaches based on theoretical cryptography and statistics
- **Sean Hallgren**: quantum computation

Faculty Awards

- PSES Outstanding Research Award
- Outstanding Teacher
- Commendation for Exceptional Leadership and Achievement in recognition of efforts as PI of the EVEREST study, from Ohio Secretary of State Jennifer Brunner
- IEEE Technical Committee on Security and Privacy Outstanding Community Service Award

Student Awards

- Graduate Research Assistant Award
- Symantec Graduate Fellowship
- N2 Women Student Fellowship
- Travel Grants
 - IEEE S&P, USENIX Security, ACM CCS, IEEE DCOSS, IEEE SECON, IEEE MASS

Prof. Trent Jaeger, (tjaeger@cse.psu.edu)

Operating Systems and VM Security, Policy Design and Analysis, Source Code Analysis

Prof. Patrick McDaniel, (mcdaniel@cse.psu.edu)

Network Security, Critical Infrastructure, Security-typed Languages, Formal Security Policy

Prof. Adam Smith (asmith@cse.psu.edu)

Cryptography, Applied Cryptography, Information Science, Theoretical Computer Science

Funding:

National Science Foundation
ARO/AFRL/IARPA
CISCO
Motorola (SERC)
Raytheon
IBM
AT&T, Samsung, ...

Ongoing Projects:

Systems and VM Security
Secure Storage Systems
Language Based Security
Telecommunications Security
Smart Grid Security
Voting Systems
Cryptography & Data Privacy



Systems and Internet
Infrastructure Security

Current Funding: Over 4.5 Million, 7 NSF grants

Recent Awards: PECASE, PSES Outstanding Research

Factoids: Established September 2004 -- Location - 344 IST Building -- Contact

siislab@cse.psu.edu

URL: <http://siis.cse.psu.edu>

MCN lab conducts research in many areas of wireless networks and mobile computing, with an emphasis on designing and evaluating mobile systems, protocols, and applications.

Projects

- secure sensor networks, collaborative data access in wireless P2P networks, mobile sensor networks, vehicular networks, resource management in wireless networks

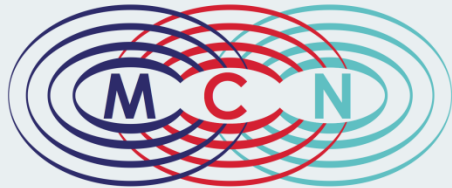

Mobile Computing and
Networking Laboratory

Students: 11 PhD, 1 MS, and 2 honor BS students

- Alumni: 6 Ph.D.
 - Faculty members at Iowa State University and Florida International University, Frostburg State University
 - Motorola lab, Cisco, Microsoft
 - 10 MS students went to various companies

Support: NSF (CAREER, ITR, NeTS/NOSS, CT, WN, CNS), Army Research Office, DoD/muri, PDG/TTC and companies such as Cisco, IBM and Narus

Contact: Prof. Guohong Cao, gcao@cse.psu.edu

URL: (<http://mcn.cse.psu.edu/>)

Faculty: Prof. Aylin Yener, yener@ee.psu.edu

URL: <http://labs.ee.psu.edu/labs/wcan>

Fundamental research on wireless communication network design

Areas: Information Theoretic Security, Capacity of Wireless AdHoc Networks, Cross Layer Design for Cognitive Radio Networks

Support

- Five awards from the National Science Foundation (NSF)
- DARPA ITMANET program
- NS-CTA

**Wireless Communications
& Networking Laboratory**

WCAN@PSU

11 Members: 1 PostDoc, Students: 8 PhD, 1 MS, 1 Undergrad

Academic collaborators:

- Penn State (NSRC), UMD, Lehigh, MIT, UT, UMN, UCI, USC, Drexel, Notre Dame, Northwestern, Stanford

Industrial Partners:

- Via NSRC

Networking and communications: enables ubiquitous connectivity

- Internet and telecommunications, ad hoc and sensor networks
- Communication and information theory
- Supported by NSF CISE; DoD (DARPA, ARL, DTRA), industry

Systems and network security: enables secure end-to-end information flow

- Secure platforms, programming languages, distributed systems, cryptography, monitoring, security management and architecture, design for security
- Internet, telecommunication and military networks
- Supported by NSF CISE; DHS, NSA, DoD, industry

Societal, business, and legal implications: enables impact on policy and deployment

- Privacy, regulation, censorship
- Financial and economic concerns, applications (e.g., supply chain)
- Applications and impact considered along with technical designs

Telecommunications Security (G. Cao, T. Jaeger, T. La Porta, P. McDaniel)

- Characterization and defenses for attacks on all aspects of telecom networks

Systems Security (T. Jaeger, P. McDaniel, S. Zhu)

- Access controls, integrity management, policy, platforms

Theory and Security (A. Smith, A. Yener)

- Information theoretic security, privacy, cryptography

Wireless Sensor Networks/MANET (G. Cao, C. Das, T. La Porta, W. Lee, S. Zhu)

- Vehicular networks, mission-oriented networks, and resource allocation

Networking and Wireless Communications (T. La Porta, J. Metzner, A. Yener)

- Network coding, relay networks, resource allocation

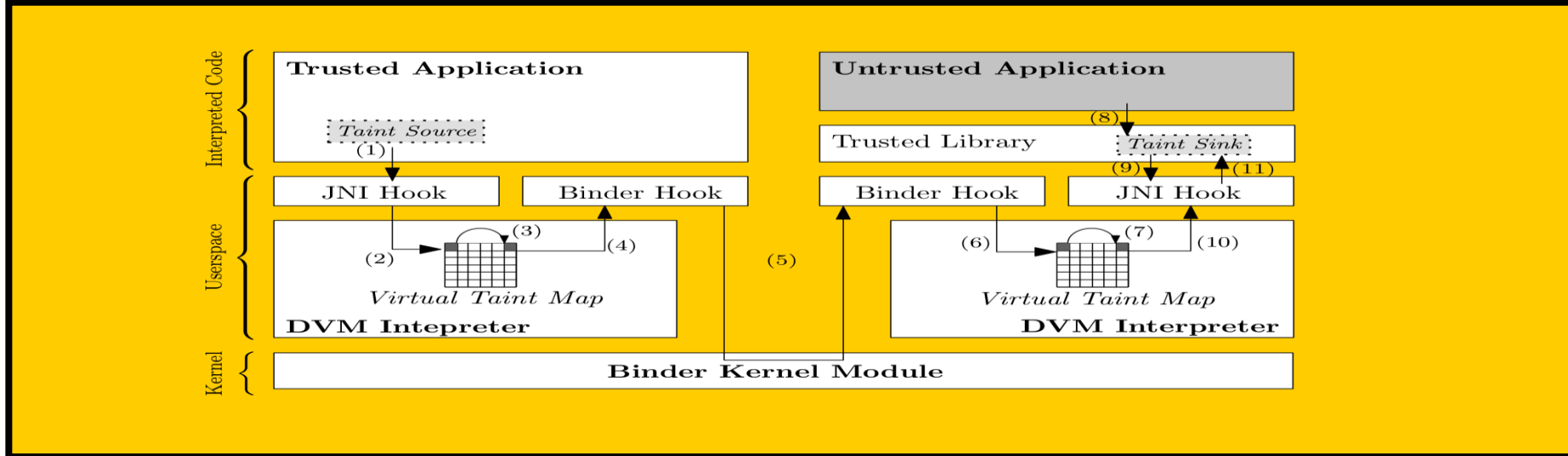

Cao, Jaeger, La Porta, and McDaniel

- Cellular network
 - Robustness of network servers (NSF, Sprint)
 - Worm containment (Narus)
- Integrity and vulnerabilities of Android devices
 - Protecting Android from tainted applications via information tracking (NSF, Intel)
 - Policy enforcement for Android (NSF)
 - Decompiling Android application to check policy (NSF)

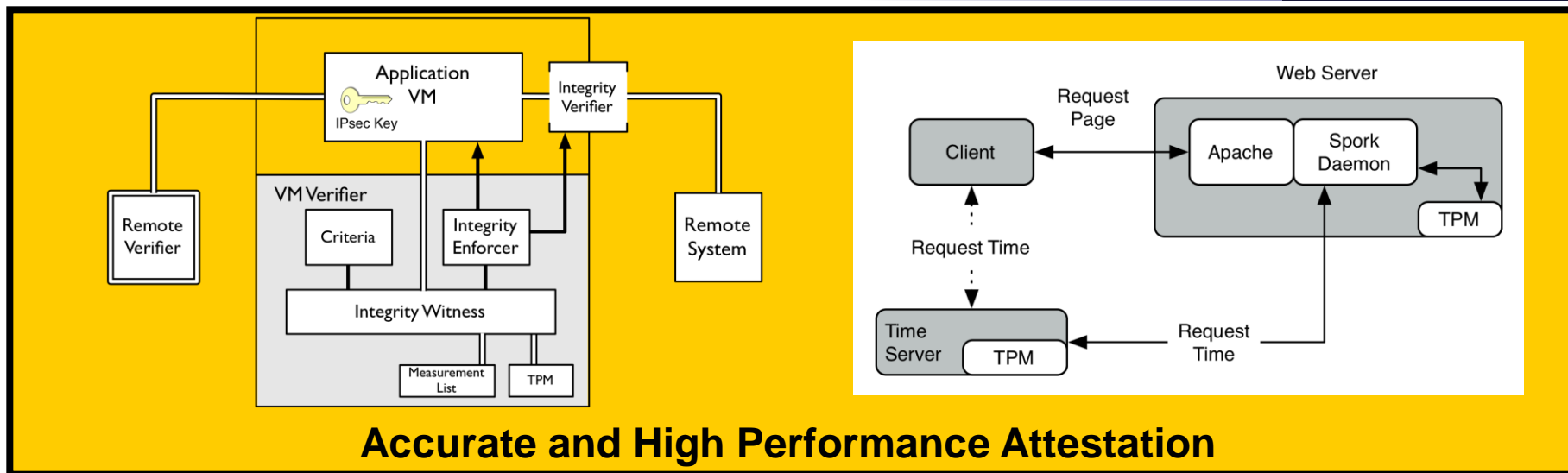

Jaeger, McDaniel and Zhu

- Platforms
 - Verify a virtual machine meets an integrity model (NSF, IBM)
 - Represent security goals and check information flows in VMs (AFRL)
 - Securing the trusted computing base of applications (NSF)
 - Retrofitting code according to security policies
 - Energy theft in metering infrastructure
 - Secure disks (NSF)
- Protection against software theft
 - “birthmarking” code
- Attestation
 - Web content attestation (NSF)

Sender



Receiver



Message

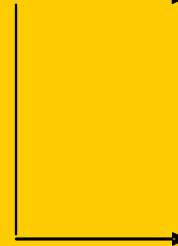

A Third Party

The receiver is convinced that the message originated from the sender

Even a malicious receiver **cannot** prove to a third party that the sender authenticated the message.

Even a malicious sender **cannot** incriminate the receiver.

Smith and Yener

- Deniable authentication (NSF)
 - Combines non-committing encryption and dual-receiver encryption
- Information theoretic security
 - Considers wire-tap channels and untrusted relays
- Privacy
 - Adhere to differential privacy to protect transactions of individuals within a database

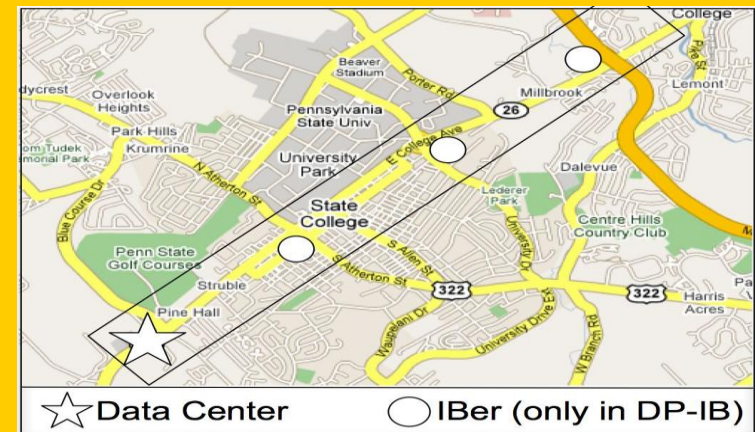
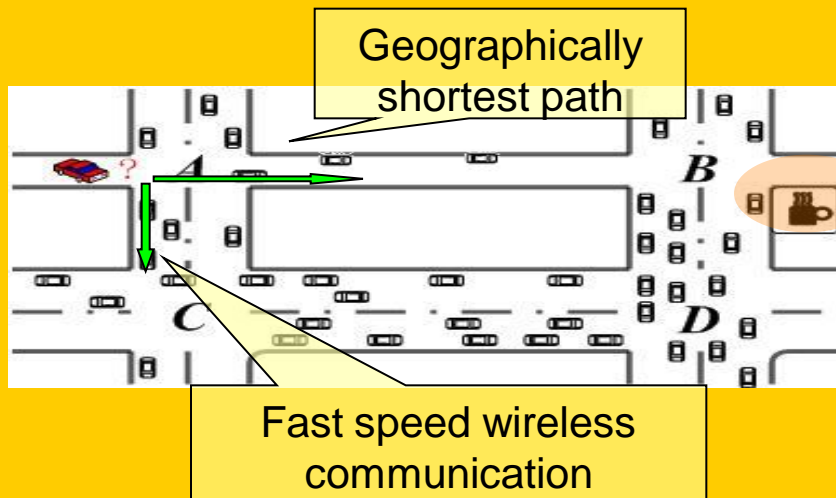

Cao, Das, La Porta, Lee and Zhu

- Optimizations for Wireless Sensor Networks (IBM/ITA)
 - Optimal energy-aware in-network processing
 - Control theoretic approach to considering mission lifetimes
 - Experimental results via implementation
- Data dissemination
 - Mission-oriented proactive push algorithms (IBM/ITA)
 - Vehicular networks
 - Mobility prediction (ARL/ITA)

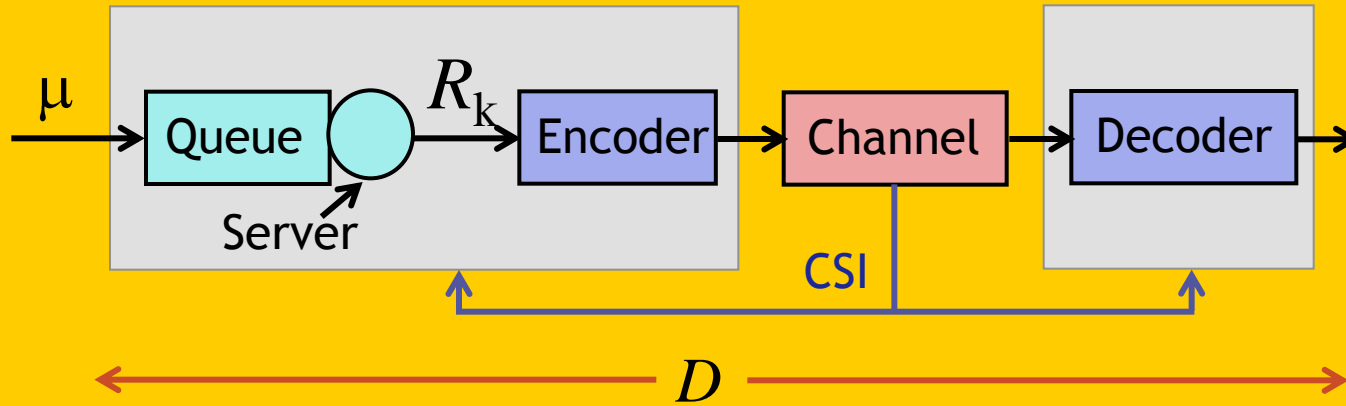

- Designed for delay (D) constrained communication
- Unique combination of coding and queuing

Cao, La Porta, Metzner and Yener

- **Network coding**
 - NC-aware rate selection in wireless multihop networks (ARO)
 - Coding in two-way relay networks (NSF)
- **Relaying in wireless networks (DARPA)**
 - Strategies in the face of interference
- **Coding**
 - Non-complex coders
- **Fault isolation (DTRA, IBM/ITA)**
 - Inferring large scale outages from passive monitoring

Faculty	Department/College	Expertise
Raj Acharya	Computer Science and Engineering (CSE)/College of Engineering (COE)	QoS
Guohong Cao	CSE/COE	Mobility, Distributed systems
Chita Das	CSE/COE	Network performance
Sean Hallgren	CSE/COE	Theory, Cryptography
Trent Jaeger	CSE/COE	Secure operating systems
Thomas La Porta	CSE&EE/COE	Mobility, Telecommunications
Wang-Chien Lee	CSE/COE	Pervasive computing
Patrick McDaniel	CSE/COE	Network Security
John Metzner	CSE & EE/COE	Reliable data communication
Adam Smith	CSE/COE	Cryptography
Aylin Yener	EE/COE	Wireless communications
Sencun Zhu	CSE/COE and IST	Network Security
Eileen Kane	Dickinson Law School	Internet Law, Policy
Jun Shu	Smeal College of Business	Supply chain, business
Russell Barton	Smeal College of Business	Supply chain, business
Akhil Kumar	Smeal College of Business	Supply chain, business
Susan Xu	Smeal College of Business	Supply chain, business
Allan Sonsteby	ARL	Networking and Comm
Chris Griffin	ARL	Decision making
Phil La Plante	Great Valley	Systems, Security
Colin Neill	Great Valley	Systems, Security
Raghu Sangwan	Great Valley	Systems, Security

Remainder of the day...

Lunch – IST Atrium

- Posters and demonstrations (outside Cybertorium, 344)

Smart Grid – 3:00

- Cybertorium

Overview of the Network Sciences Communications Technology Alliance – 3:30

- Cybertorium

Center Discussion - 4:00

- Room 333 (Industry guests only)

Dinner – 6:00 at The Tavern

Tomorrow

Faculty talks – 9:00 – 1:00 (lunch included)

- 333 IST Building

Education

- PhD, Columbia University, Electrical Engineering

Background

- Director of Mobile Networking Research at Bell Labs until 2002

Professional Activities

- Member, Board of Governors, IEEE Communications Society, 2007-
- Director of Magazines, IEEE Communications Society, 2006-2007
- Past Editor-in-Chief, IEEE Applications and Practice Magazine
- Founding Editor-in-Chief, *IEEE Transactions on Mobile Computing*, 2001-2004
- Past Editor-in-Chief, *IEEE Personal Communications*
- General Chair, *IEEE MASS*, 2008
- Program Chair, *IEEE Percom*, 2007
- General Co-Chair, *Mobiquitous*, 2006
- General Co-Chair: *ACM Mobicom 2005*
- Member, Steering Committee, *IEEE Transactions on Mobile Computing*, *IEEE/ACM Transactions on Networking*

Awards

- Bell Labs Fellow
- IEEE Fellow
- Thomas Alva Edison Patent Award 2007, 2009
- Bell Labs Distinguished Technical Staff Award
- IEEE Computer Society Golden Core Member

Expertise

- Mobile networking, wireless networking, secure telecommunication network signaling and control, protocol design

Support

- National Science Foundation
- Army Research Lab/UK MoD, ITA Program (IBM Prime)
- Army Research Lab NS-CTA Communications Network Center (lead)
- DTRA
- Technology Collaborative
- IBM, Raytheon, Accipiter Systems, Vocollect, Cisco, Sprint
- NSRC

- **Sensor Information Processing**
 - Mission specific network configuration and data collection
 - Data dissemination
- **Secure all-IP Mobile Telecommunication Networks**
 - Combat (exploit) threats introduced by interfaces to IP networks
- **Resource in ad hoc wireless networks**
 - Applied to network coding
- **Security for sensor and ad hoc networks**
 - Privacy and clone detection
- **Node mobility for Robust Mission-Oriented Sensor Networks**
 - Deployment and relocation strategies for sensors

Education

- PhD, Ohio State University, Computer Science

Professional Activities

- Associate Editor, *IEEE Transactions on Mobile Computing*
- Associate Editor, *IEEE Transactions on Wireless Communications*
- Guest Editor, *ACM MONET special issues on Heterogeneous Wireless Networks, 2006*
- *Program chair, IEEE International Symposium on Reliable Distributed Systems (SRDS), 2009*
- *General Chair, Int'l Conf. on Mobile and Ubiquitous Systems (MobiQuitous), 2007*
- Program Vice Chair: *IEEE Int'l Conf. on Distributed systems, 2009*
- Program area chair, infocom, 2008
- Program committee of *ACM MOBICOM, IEEE INFOCOM, ACM MOBIHOC, IEEE ICNP*

Awards

- Presidential Fellowship at the Ohio State University
- NSF CAREER, 2001

Expertise

- Mobile computing, wireless networks, sensor networks, wireless network security, distributed fault-tolerant computing, resource management and data dissemination in mobile environments

Support

- NSF (ITR, CAREER, NeTs/NOSS, WN, CT, CNS)
- Army Research Office
- PDG/TTC
- DoD/MURI

- **Collaborative Data Access in Mobile Peer-to-Peer Networks**
 - Improves performance in constrained environments through collaboration.
- **Controllable Node mobility for Mission-Oriented Sensor Networks**
 - Deployment and relocation strategies for sensors
- **Secure Wireless Sensor Networks**
 - Defend against node compromises; self-healing mechanisms for sensor networks
- **Data dissemination in vehicular ad hoc networks**
 - Reduce data access delay and exploit mobility pattern to assist data delivery.
- **A Data-Centric Framework for Target Tacking and Data Dissemination in Sensor Networks**
 - New architecture for wireless sensor networks
- **Designing Efficient Resource Management Schemes to Support Integrated Services in Mobile Computing Systems**
 - Consider both power issues and QoS issues
- **Efficient Power Aware Data Access in Pervasive Computing Environment**
 - Consider both single-hop and multi-hop models

Co-Director of the Systems and Internet Infrastructure Security Lab: <http://siis.cse.psu.edu>

Education

- PhD, University of Michigan, Electrical Engineering and Computer Science

Professional Activities

- **Program Co-Chair**, *2007 and 2008 IEEE Symposium on Security and Privacy*, May 2007, May 2008.
- **Program Chair**, *15th USENIX Security Symposium*, August 2005.
- **Vice-Chair**, *Security and Privacy Track, 14th World Wide Web Conference (WWW)*, May 2005.
- **Program Chair**, *Industry Track, ACM Conference on Computer and Communications Security (CCS)*, November 2004, 2007.
- **Editor-in-Chief**, *ACM Transactions on Internet Technology (TOIT)*, April 2004-present.
- Associate editor, *ACM Transactions on Information and System Security (TISSEC)*, Summer 2007.
- Associate editor, *IEEE Transactions on Software Engineering (TSE)*, Spring 2007.
- Associate editor, *IEEE Transactions on Computers (TC)*, Spring 2007.
- Area editor, *IEEE Security and Privacy Magazine*, Spring 2008
- Program Committee Member (2005): *ESORICS, ACSAC, ACNS, CCS, ICIS, ACM EC, SACMAT, SNS, ACNS, USENIX Security, USENIX Technical, many more*

Expertise

- Systems security, security policy, telecommunications security, network security, digital rights management, digital content and public policy, network management, applied cryptography, privacy

Current Support

- PI, Secure Provenance in High-End Computing Systems, NSF, \$307,073, (08/1/09-8/31/06).
- PI, Security Services in Open Telecommunications Networks, NSF, \$594,941, (08/01/09-08/01/12).
- PI, Characterizing and Mitigating Wireless Systems Vulnerabilities, Defense University, ARO, \$150,000, (05/22/09-05/21/10).
- PI, Integrity Management for ICT Development, Alcatel-Lucent, \$100,000, (11/30/08-11/30/09).
- PI, Utility Grid Automation and Risk Management, Lockheed Martin, \$400,000, (11/30/08-12/16/09).
- Co-PI, Protecting Services for Emerging Wireless Telecommunications Infrastructure, NSF, \$658,032, (09/01/07-08/31/11).
- PI, CAREER: Realizing Practical High Assurance through Security-Typed Information Flow Systems, NSF, \$400,000, (1/2/07-1/1/12).
- Co-PI, CT-IS: Shamon: Systems Approaches for Constructing Distributed Trust, NSF, \$400,000, (9/1/06-8/31/10).
- Co-PI, Exploiting Asymmetry in Performance and Security Requirements for I/O in High-end Computing, NSF, \$699,690, (9/1/06-8/31/11).

- **Shamon: Systems Approaches for Constructing Distributed Trust**
 - Extending mandatory access control from applications, to operating systems, to distributed environments
- **Secure Provenance in High-End Computing Systems**
 - Developing provenance applications for huge/distributed computational environments
- **Scalable Asynchronous Web Content Attestation**
 - Making integrity measurement services scale to commercial loads
- **On Attack Causality in Internet-Connected Cellular Networks**
 - Understanding and fixing evolving threats in cellular phone systems
- **Exploiting Asymmetry in Performance and Security Requirements for I/O in High-end Computing**
 - Exploring performance/security tradeoffs in large-scale distributed storage

Rootkit-Resistant Disks

- Exploiting advanced disk processor capabilities to restrict rootkit infections
- **On Lightweight Mobile Phone App Certification**
 - Investigating automated means of validating security of cell phone at install

Co-Director of the Systems and Internet Infrastructure Security Lab: <http://siis.cse.psu.edu>

Education

- PhD, University of Michigan, Electrical Engineering and Computer Science

Professional Activities

- **Program Chair**, ACM Computer Security Architectures Workshop (with ACM CCS), October 2008
- **Program Chair**, USENIX Workshop on Hot Topics in Security, August 2007.
- **Program Chair**, Industry Track, *ACM Conference on Computer and Communications Security (CCS)*, November 2003.
- **Program Chair**, *ACM Symposium on Access Control Models and Technologies*, 2001.
- Associate Editor, [ACM Transactions on Internet Technologies](#) (TOIT), 2007-
- Guest editor, [ACM Transactions on Information Systems Security](#) (TISSEC), November 2002.
- Program Committee Member: [IEEE Security and Privacy](#), [ESORICS](#), [ACSAC](#), [NDSS](#), [CCS](#), [USENIX Security](#), [WWW \(security\)](#), [SACMAT](#), many more
- Active participant in the Linux security community, including the development of open source code (kernel and systems applications) and an organizer of the yearly Security-Enhanced Linux Symposium.

Expertise

- Host security, operating systems, source code analysis, security policy, secure hardware, distributed security architectures, embedded systems security

Current Support

- PI, *National Science Foundation*, CNS-0905343, Techniques to Retrofit Legacy Code for Security, September 2009-September 2012, \$1,200,000 (with Wisconsin, Purdue, Maryland).
- Co-PI, *National Science Foundation*, CNS-0931914, Establishing Integrity in Dynamic Networks of Cyber Physical Devices, September 2009-September 2012, \$600,000 (with Rutgers).
- PI, *Air Force Research Lab (AFRL)*, Policy Design and Analysis for XSM/Flask, June 2008-December 2009, \$392,000
- Co-PI, *National Science Foundation*, CNS-0721579, Protecting Services for Emerging Wireless Telecommunications Infrastructure, September 2007-September 2010, \$400,000.
- PI, *Disruptive Technology Office* (now IARPA), System-Wide Information Flow Enforcement, February 2007-August 2008, \$500,000.
- PI, *National Science Foundation*, CNS-0627551, Shamon: Systems Approaches to Composing Distributed Trust, September 2006-September 2010, \$400,000.

- **Xen Policy Design Tools**
 - Verify that virtual machine system policies (e.g., Xen’s XSM/Flask and SELinux policies for the various VMs) all *comply* with system security goals
- **Retrofitting Security in Legacy Code**
 - Develop source code analysis approaches and tools to (mostly) *automate the addition of security code* (e.g., authorization) to legacy applications (in Java and C)
- **System Integrity**
 - Develop practical models of system integrity (displaying risk, rather than requiring its complete abolition), build tools to identify integrity risks in systems and measure such risks quantitatively
- **Hardware-based Integrity Measurement**
 - Explore approaches for *usable hardware-based integrity measurement* and apply such techniques to virtual machine systems
- **Shamon: Systems Approaches for Constructing Distributed Trust**
 - Extend *Mandatory Access Control guarantees* in breadth (at Internet scale) and depth (across the application, system, and network layers)
- **Virtual Machine Security**
 - Extend *Xen mechanisms* to configure end-to-end security for distributed, virtual machine systems
- **Mobile Phone Systems Security**
 - Identify attacks and propagation methods for attack and develop MAC policies and integrity measurement techniques to *verify integrity of key system components* (installer and telephony)

Member, Systems and Internet Infrastructure Security (SIIS), Algorithms and Complexity groups

Education

- PhD, M.I.T., Electrical Engineering and Computer Science

Professional Activities

- **Associate Editor**, *Journal of Privacy and Confidentiality*
- **Program Committee Member**: *Crypto*, *WWW*, *ACM Electronic Commerce*, *Theory of Cryptography*, *RSA - Cryptographer's Track*, *SODA*, ...

Expertise

- Cryptography, privacy in statistical databases, quantum computing, information theory

Awards

- Presidential Early Career Award for Scientists and Engineers (PECASE)
- NSF CAREER Award
- Microsoft Graduate Fellowship

Current Support

- PI, CCF: Algorithmic and learning-theoretic aspects of data privacy, NSF, \$278,000
- PI, CAREER: Rigorous Foundations for Data Privacy, NSF, \$400,000

- **Privacy in Statistical Databases**
 - Conceptual tools for rigorous analysis
 - Design of “robust” algorithms for machine learning and statistical estimation
 - Attacks based on publicly available information sources
- **Cryptographic Protocols**
 - Secure Function Evaluation: efficient distribution of computation and secret data among mutually untrusting network of participants
 - Deniable Authentication and Key Exchange: Stronger Models for Complex Networks
 - Efficient public-key encryption with rigorous security analysis
- **Key Extraction from Biometrics and Other “Noisy” Secrets**
 - Generation of reliable and secret keys/passwords from biometric data
- **Quantum Information and Cryptography**
 - Understand and limit use of quantum information processing to break deniability and zero-knowledge in cryptographic protocols

Education

- Ph.D. in Information Technology from George Mason University (Aug. 2004)

Recent Professional activities

- Program Co-Chair: ACM SASN'06
- TPC member: ACM CCS'07, IEEE Infocom'07, ESORICS'08, ACM WiSec'09
- Treasurer: ACM CCS'07, '08, '09

Expertise

- Network and systems security, applied cryptography
- Ad hoc and sensor network security
- Peer-to-peer computing Security
- Code security

Current Support

- NSF CAREER Award

- **Security and Reliability for Sensor Networks**
 - Source location anonymity
 - Applications of sensor networks to vehicle-theft detection
 - Secure data aggregation
- **Security for Ad-hoc Networks/Delay-Tolerant Network (DTN)**
 - Traceback of compromised nodes in mobile ad hoc networks
 - Key management, authentication, DoS prevention in DTN
- **Security for Peer-to-Peer Networks**
 - Worm containment through active patching
 - Pollution detection
- **Code Security**
 - Blocking buffer overflow attacks by static code analysis and data mining
- **Security for Cellular Network**
 - Detecting and containing cell phone worms

Education

- Ph.D. in Computer Science, U.C. Berkeley

Professional Activities

- Editorial board, Theoretical Computer Science

Background

- Senior Research Scientist and head of Quantum Information Technology, NEC Labs
- NSF Mathematical Sciences Postdoctoral Fellowship, Caltech Department of Computer Science and the Institute for Quantum Information

Expertise

- Quantum computation, quantum algorithms

Support

- NSF, ARO

Projects

- Algorithms for quantum computers
- Security of classical cryptosystems against quantum attacks

Education

- PhD, Wireless Information Network Laboratory (WINLAB), Rutgers University

Background

- NSF CAREER Award, 2003
- Research group: [Wireless Communications and Networking Laboratory: WCAN@PennState](#)

Selected Professional Activities

- IEEE Information Theory Society Student Committee Chair (Sept. 2007-Present)
- IEEE Transactions on Wireless Communications, Editor (2001- Present)
- General chair, Second Annual School of Information Theory, Chicago, IL, July 2009.
- General chair, First Annual School of Information Theory, University Park, PA, June 2008.
- Chair, Communication Theory Symposium, IEEE Int. Conf. on Communications, ICC 2009.
- Co-chair, Wireless Communication Symposium, IEEE Int. Conf. on Communications, ICC 2008.
- Chair, Asilomar Conference Communications Track (2008 & 2005); Co-chair, WirelessCom Symposium on Information Theory (2005); TPC member in *IEEE Globecom*, *ICC*, *VTC*, *WCNC* (yearly)

Expertise

- Information theory, physical layer security, cross-layer design, relay networks, MIMO, CDMA.

Support

- **NSF:**
 - **CAREER (CCF) – Multiuser Multi-antenna Communications**
 - **CCF – Information Theoretic Security**
 - **CNS – NeTS Multi-tier Hybrid Wireless Networks**
 - **CNS – NeTS Cognition, Cooperation, Competition in Wireless Networks**
 - **CNS – CT Secure Capacity of Wireless Networks**
- **DARPA:** Information Theory for Mobile Ad Hoc Networks (**ITMANET**)

- **Capacity of Mobile Ad Hoc Networks (MANETs)**
 - Development of a new fundamental theory for information transfer for MANETs.
- **Secure physical layer design for multiuser systems/wireless networks**
 - Secure physical layer design for wireless communications.
 - Information theoretic security.
 - Cooperation for security.
 - Security for heterogeneous ad hoc networks.
- **Relay networks/Hybrid networks and cooperative communications**
 - Physical layer design for networks that relay information on behalf of other nodes, network formation, transmission strategies, impact of physical layer on MAC/routing.
 - Distributed resource allocation algorithms.
 - User cooperation strategies, multiuser relay networks.
 - Two-way relaying.
 - Network Coding.
- **Cross-layer design for Ad Hoc wireless networks**
 - Cognitive relay networks
 - Throughput optimal scheduling for Ad Hoc networks with PHY enhancements and Network Coding

Education

- Ph.D., University of Louisiana

Background

- IIT Kharagpur (India)
- Joined Penn State in 1986

Awards

- IEEE Fellow
- Best Paper Awards (ICPP, ICDCS, PRDC)
- CSE Dept Teaching Award

Expertise

- communication networks & communication mechanisms; resource management (scheduling); QoS support in clusters and Internet; mobile computing; performance evaluation; parallel distributed computer architectures; clusters; fault-tolerant computing

Support

- NSF (scheduling, QoS, Infrastructure), Unisys (performance)

- **Dynamic Quarantine of Unresponsive TCP Flows**
 - Detect and isolate non-conforming TCP flows
- **Adaptive AQM Schemes for Internet and Wireless Networks**
 - Improve performance of Internet and limited wireless networks
- **QoS Provisioning in InfiniBand Architecture (IBA) for System Area Networks**
 - Design and analysis of IBA-style SANs
- **Scalable and Efficient Scheduling Techniques for Clusters**
 - Aims at developing practical scheduling techniques for large clusters
- **Performance Analysis with Commercial Workloads**
 - Analysis of TPC-C workloads
- **Design of Cluster-based Datacenters**
 - Design of 3-tier data centers on cluster platforms
- **Design and Analysis of System-on-Chip (SoC) Interconnects**
 - Design of on-chip interconnects considering area, power and reliability constraints

Education

- PhD, Ohio State University

Background

- 1996 - 2001, GTE/Version Research Laboratories, Inc.
- Research group at Penn State (2002-Present): Pervasive Data Access Research Group (<http://www.cse.psu.edu/pda>)

Awards

- Excellence Award: GTE/Verizon Laboratories Incorporated (1997, 1999, 2000).
- Achievement Award: GTE/Verizon Laboratories Incorporated (1999).

Professional Activities

- Guest Editor, IEEE Transaction on Computer, IEEE Personal Communication Magazine, ACM Mobile Networks and Applications (MONET), ACM Wireless Networks (WINET)
- Technical Program Chair: International Conference on Mobile Data Access (1999); International Workshop on Pervasive Computing (2000); International Workshop on Wireless Networks and Mobile Computing (2000/2001). International Workshop on Peer-to-Peer Information Management (2006); International Conference on Scalable Information Systems (2007);
- Industrial Program Chair: International Conference on Mobile Data Management (2001-2002).
- Steering Committee: International Conference on Mobile Data Management
- TPC Member (2006): ICNP, ICDE, ICDCS, SAC, DASFAA, INFOSCALE, PERCOM

Expertise

- Pervasive Computing, Wireless Networks, Network Services, Data Management, TMN

Current & Past Support

- NSF, ARDA, GENUITY, RGC (Hong Kong)

• Location-Based Information Access in Pervasive Computing

- Investigate new ways of indexing and caching spatial data in support of location based services in pervasive computing environments.

• Semantic Small World: A Multi-Dimensional Overlay Network

- Design of a multi-dimensional overlay network, called *semantic small world* (SSW), that facilitates efficient semantic based search in P2P systems.
- SSW is adaptive to distribution of data and locality of interest; is very resilient to failures; and has great load balancing property.

• Location-Aware Wireless Sensor Networks

- Design of a suite of protocols, algorithms and services to provide energy-aware, time-efficient, robust and scalable location-aware wireless sensor networks.
- Tackled research issues include communication collisions, communication voids, packet losses, location errors, scalability, service latency and validity of services.

• Automata-Based XML Access Control for Networked Computing

- Design of a new XML access control mechanism, called QFILTER, for Internet-scale networked information systems.

• Secure Wireless Data Broadcast

- Development of new air indexing and key management techniques to address the security concerns in wireless data broadcast systems.

Education

- Eng. Sc. D., New York University

Background

- Acting director of the Computer Engineering Program in Electrical Engineering (two years)
- Acting Dean, School of Engineering and Computer Science, Oakland University, Rochester 1974-1980
- Professor, Electrical Engineering, Wayne State University, Detroit, Michigan
- Associate Professor, Electrical Engineering New York University
- Associate Professor, Polytechnic Institute of New York
- Research Scientist, Electrical Engineering Department, New York University

Awards

- IEEE Fellow
- Fellowships: Link Aviation, National Science Foundation, David Sarnoff
- IEEE Computer Society Distinguished Speaker/Visitor

Expertise

- ARQ protocols for reliable and efficient data communication, methods for efficient comparison of remote replicated data files, efficient reliable and secure multicasting, improved utilization of ALOHA in multi-access, error correction techniques, efficient use of wireless network resources

Support

- Many previous grants from NSF

- **Vector and packet symbol decoding**
 - Discovered a new packet-symbol decoding method for reliable communication despite errors, deletions, out-of order packet receptions, no sequence numbers and no per-packet error detection. Working on extending idea to very long codes, convolutional codes.
 - Method discovered for enhanced and simpler burst error correction of vector symbol codes.
 - Applications to multi-reception code combining with vector symbol codes
- **Reliable multicasting**
 - Efficient methods of gathering acknowledgments with a tree topology and a virtual ring
 - Improved efficiency by cooperation of local network stations Ultra wideband or light traffic ALOHA
 - Increased value of hop-by-hop versus end-to-end error control in multicasting.
- **Multi-user networks**
 - Improved efficiency by cooperation of local network stations Ultra wideband or light traffic ALOHA
 - Reliable communication from a mobile to a network of cooperating base stations or to other stations in an Ad Hoc network for minimal interference and energy utilization.
 - Window controls and acknowledgment protocols for efficient multi-path wireless routing to a base station or multi-base network.
- **Secure Reliable Multicasting (SAM)**
 - Simple acknowledgment and key changing for combined secure and reliable multicast in moderate size groups

Education

- PhD, University of Minnesota, Mayo Graduate School of Medicine

Background

- Research Scientist, Mayo Clinic
- Research Scientist, GE (Thomson)
- Faculty Fellow, Night Vision Laboratory, Fort Belvoir, Washington, D.C.
- NASA-ASEE Faculty Fellow, Johnson Space Center, Houston, TX
- Director, Advanced Laboratory for Information Systems and Analysis

Professional Activities

- General Chair, *SPIE International Conference on Physiology and Function from Multidimensional Images*
- Co-Chair, *IEEE Workshop on Biomedical Image Analysis*
- General Chair, *SPIE Conference on Biomedical Image Processing*
- Associate Editor, *International Journal of Computerized Medical Imaging and Graphics*

Expertise

- Net-centric computing, resource management for ad hoc networks, information fusion, bioinformatics, data mining

Support

- NSF ITR

Education

- PhD, The Pennsylvania State University, Electrical Engineering

Background

- Industry, Government, and Academia

Professional Activities

- Futures panel for Undersecretary of Defense for Intelligence
- Chairman, NATO SCI-106 (U. S. Representative) – 2000 – 2003
- Chairman, NATO SCI-030 (U. S. Representative) – 1997 – 1999
- Member, Institute of Electrical and Electronics Engineers (IEEE)
- Member, U. S. Government Low Probability of Intercept Communications Committee
- Member, Eta Kappa Nu (EE Honor Society)

Awards

- U. S. Representative to NATO Research Study Group-106 “Vulnerabilities of Mobile Tactical Communication Systems”
- U. S. Representative to NATO Research Study Group-030 “Communications-EW Control and Coordination”
- Eta Kappa Nu
- GTE Corporation Graduate Fellowship Recipient

Expertise

- Signal processing, Geolocation/Target tracking

Support

- Manages approximately \$42M annually of research sponsored by Government and Industry

Education

- PhD, Penn State University, Operations Research

Background

- Staff scientists Oak Ridge National Laboratory
- Seven years as staff engineer Penn State Applied Research Laboratory

Awards

- Wigner Fellow (Oak Ridge National Laboratory)

Expertise

- Data fusion, control theory, social network analysis

Support

- Office of Naval Research
- Intelligence Advanced Research Projects Agency
- U.S. Government
- Oak Ridge National Laboratory Internal Research and Development

- **Learning and Prediction for Enhanced Readiness and Decision Making (LEPERD)**
 - Apply non-linear hybrid statistical methods to the problem of track learning and anomaly detection.
 - Test results on live data sets provided by sponsor and scrapped from the open source.
- **Combined Hierarchical Environment for Tracking Anomalies with Hybrid Statistics (CHEETAH)**
 - Enhance work done in LEPERD to use categorical data of the type found in ship manifests.
 - Create a prototype anomaly detection system and test at appropriate field location.
- **Deep Social Network Analysis**
 - Extend beyond classical social network analysis by integrating message internal data.
 - Formalize social science theories in mathematical equations and algorithms and apply them to detecting patterns within human networks.

Education

- PhD, University of California at Berkeley, Industrial Engineering and Operations Research

Professional Activities

- *Program co-Chair, INFORMS TELECOM National Conference, 2005*
- *Program co-chair, INFORMS National Conference E-Business Section, 2006*

Grants

- IBM Research Grant 2004
- Smeal Research Grants 2005-2008
- NSF Grant 2007

Expertise

- Network Management and Pricing
- Supply Chain Management
- Management of Information Systems
- Game Theory

Industry Experience

- MCI
- Cisco
- Rockwell Semiconductor

- **Piecemeal Hybrid P2P Networks for Large Scale Content Distribution**
 - How to deliver 30,000 TV Channels with excellent quality to customers and scalable infrastructure requirement to providers?
- **Supply Chain Execution Control via Individualized Trace Data**
 - How to manage an execution process over networks with large volumes of real-time trace data?
- **Service Family Design**
 - How to design and provision services like we do in product family design?
- **Compatibility Standards through Collaboration**
 - How to decide which standards to invest in at the early stage of a technology adoption?

Education

- PhD (Computer Science), Stevens Institute of Technology

Background

- Software Engineer, Singer-Kearfott Navigation Systems
- Member, Technical Staff, Bell Labs Software Quality Assurance Center
- CTO, Eastern Technology Council
- Registered Professional Engineer (Pennsylvania)
- Certified Software Development Professional

Professional Activities

- Board of Governors, *IEEE Computer Society*
- Administrative Committee, *IEEE Reliability Society*
- Editor (Software Engineering), *ACM Computing Reviews*
- Editorial Board, *Advances in Software Engineering*
- Associate Editor, *IT Professional*

Expertise

- Requirements Engineering, Software Testing, Software Project Management.

Support

- Analytical Graphics
- Primavera Software

Education

- PhD, University of Wales, Software and Systems Engineering

Professional Activities

- Associate Editor-in-Chief, *Innovations in Systems and Software Engineering: A NASA Journal*
- Member, Advisory Board, *International Journal of Advanced Manufacturing Technology*.
- *General Chair, ASQ National Quality Month Symposium on Software and Systems Quality, 2007*
- Program committee of *ICECCS 2006, NASA/IEEE SEW 2002-2007*.

Expertise

- Software engineering; software architecture, requirements engineering, system quality, system complexity

Previous Support

- British Aerospace, Systems & Equipment
- Rover Cars
- EPSRC, UK

- **Driving Architectural Design from Business and Technical Goals**
 - Ensuring architectures embody systemic qualities reflecting both business and technical goals
- **Agile and Distributed Software Development**
 - Hybrid processes that allow flexibility and agility without loss of comprehension in global development
- **Strategic Refactoring and Design Repair**
 - Repairing legacy systems that have evolved and eroded.
- **Software Engineering Best Practices**
 - Monitoring and assessing the common and best practices employed in industry.
- **Analysis of Large and Ultra-Large Software Systems**
 - A methodology for measuring and monitoring software complexity that can be used to effectively manage software systems so they do not become overly complex.

Education

- PhD, Temple University, Computer and Information Sciences

Professional Activities

- General Chair, Working IEEE/IFIP Conference on Software Architecture, 2011
- Program Committee, International Workshop on Requirements Engineering Visualization, 2006 – 2009, IEEE International Conference on Global Software Engineering, 2006 – 2009, Working IEEE/IFIP Conference on Software Architecture, 2006 – 2009, International Conference on the Quality of Software Architecture, 2008 – 2009
- Reviewer, IEEE Software, Journal of Software and Systems, Journal of Software Process: Improvement and Practice, Computing Reviews.

Expertise

- Analysis, design, and development of large scale software-intensive systems, and automatic and semi-automatic approaches to assessment of their quality and complexity

Previous Support

- Siemens Corporate Research
- Software Engineering Institute, Carnegie Mellon University

- **Software architecture analysis and design**
 - Quality-based approaches to creating software-intensive systems
 - Integrating quality-based approaches into mainstream software systems design methodologies
- **Characterizing essential and incidental complexity**
 - Multidimensional approaches to studying structural complexity in software-intensive systems
 - Development methodologies and their influence on structural complexity of software-intensive systems
- **Architecture drift and erosion**
 - Software evolutionary studies revealing system decay
 - Strategies for preventing architecture drift and erosion leading to system decay